

# MLC PERT/AL/PERT PIPES



## MLC PERT/AL/PERT PIPES

MLC (Multilayer Composite Pipe) PERT/AL/PERT is formed with outer PERT type II layer (Polyethylene of raised temperature resistance), intermediate butt welded ("head to head") aluminium layer and inner PERT type II layer.

### 1. MULTILAYER PIPE CHARACTERISTICS

- Supports temperature up to 95°C at up to 10 bar pressure and the mechanical resistance tests can be performed up to internal pressure 20 bar at 20°C temperature.
- Occasionally can support maximum temperature up to 110°C at design pressure based on regression curve.
- Can be bended manually maintaining the permanent shape and curvature.
- Tight to oxygen diffusion.
- Corrosion, abrasion and chemical products attack resistance.
- Very few pressure drops and low noise transmission.
- No adhesion or incrustation.
- Sanitary quality. The plastic pipes are totally non-toxic and do not alter the properties of the transported fluid (colour, taste, odour).
- Low thermal conductivity reduces the condensation and the heat losses.
- Meet the advantages of metal and thermoplastic pipes.
- Visually esthetic in non embeded plumbing and heating installations.
- Environment friendly.
- Low linear dilatation (at the level of metal pipes).
- FITTINGS ESTÁNDAR multilayer pipes fulfill with "Hygienic-sanitary criteria of the quality of water for human consumption" established in Royal Decree 140/2003
- Fittings Estándar PEX/AL/PE multilayer pipe holds AENOR certification for Press fitting system.

# MLC PERT/AL/PERT PIPES

## 2. MLC PERT/AL/PERT PIPE COMPOSITION

Fittings Estándar MLC pipes are composed of 5 layers:

1. Outer PERT type II layer
2. Adhesive layer
3. Intermediate aluminium butt welded ("head to head") layer
4. Adhesive layer
5. Inner PERT type II layer.

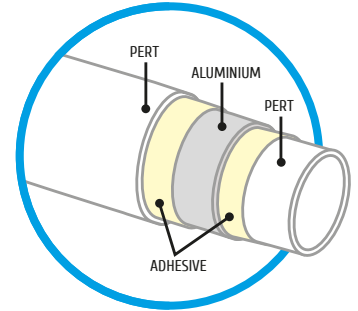

## 3. MULTILAYER PIPE APPLICATIONS

Multiple applications:

- Plumbing installations
- Underfloor heating and radiator heating installations
- Cooling installations
- Protection of electric wiring installations
- Application in food and automotive industry.

## 4. MULTILAYER PIPE TECHNICAL CHARACTERISTICS

Características mecánicas	Valor	Unidad	Norma
Max. work temperature	95	°C	ISO 21003
Max. point temperature	110	°C	ISO 21003
Max. work pressure	10	bar	ISO 9080-ISO 21003
Linear dilatation	0,025	mm/m °K	ASTM D-696
Thermal conductivity at 60 °C	0,40	W/m °K	DIN 52612-1
Coefficient of linear expansion	1,8	10 <sup>-4</sup> /K	DIN 53752 A
Minimum operating temperature	5°C (avoid freezing )		
Softening point temperature	+100	°C	
Thermal conductivity	0,42	W/mk	
Roughness coefficient	0.007 mm		
UV Resistance	NO		
Halogen	Halogen free		

# MLC PERT/AL/PERT PIPES

## 5. DESIGN CONDITIONS ACCORDING TO UNE-EN ISO 21003

Application field	Value	Conditions	Temperature	Years
Supply	10 bar	Design	20	50
1. Hot water supply (60 °C)	6 bar	Design temperature	50	49
		Tmax.	80	1
		Tmal.	95	0.0114
2. Hot water supply (70 °C)	6 bar	Design temperature	70	49
		Tmax.	80	1
		Tmal.	95	0.0114
4. Underfloor heating and low temperature radiators	6 bar	Design temperature	20	2.5
		Tmax.	40	20
		Tmal.	60	25
		Tmal.	70	2.5
		Tmal.	100	0.0114
5. High temperature radiators	6 bar	Design temperature	20	14
		Tmax.	60	25
		Tmal.	80	10
		Tmal.	90	1
		Tmal.	100	0.0114

## 6. MINIMUM RADIUS OF CURVATURE RECOMMENDED

Dimension	Manual	With internal spring	With tool
16x2,0	78	62	48
18x2,0	88	70	55
20x2,0	98	78	60
25x2,5	126	98	80
32x3,0	196	158	150